

PART NAME	MATERIAL	REMARK
FRAME	SIDE RAIL	SM490A
	END RAIL	SM490A
	CORNER POST	SM490A
	CROSS MEMBER	SM490A
PANEL	DOOR	CORTEN A
	ROOF	CORTEN A
	SIDE	CORTEN A
	FRONT	CORTEN A
WOODEN FLOOR	PLYWOOD	APITONG/KERUING PLYWOOD
DOOR LOCKING ROD ASS'Y	"HH-EA/1" TYPE	

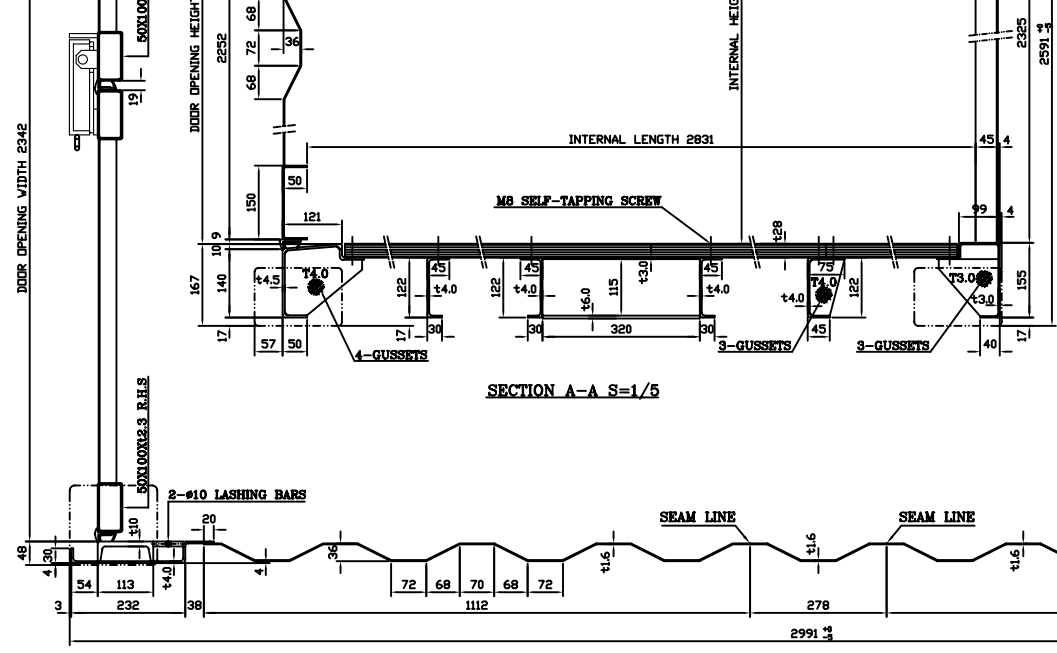

DRAWING NO.	DESCRIPTION	REMARK
BZ10-1.01.00.0	BASE ASSEMBLY	
BZ10-1.02.00.0	FRONT ASSEMBLY	
BZ10-1.03.00.0	DOOR ASSEMBLY	
BZ10-1.04.00.0	SIDE ASSEMBLY	R/H:1 L/H:1
BZ10-1.05.00.0	ROOF ASSEMBLY	
BZ10-1.06.00.0	MARKING	
CLASSIFICATION		DIMENSION
EXTERNAL	LENGTH	2,991 +0/-6mm 9' 9 3/4" +0/-1/4"
	WIDTH	2,438 +0/-5mm 8' 0" +0/-3/16"
	HEIGHT	2,591 +0/-5mm 8' 6" +0/-3/16"
INTERNAL	LENGTH	2,831 +0/-6mm 9' 3 25/64" +0/-1/4"
	WIDTH	2,350 +0/-5mm 7' 8 29/64" +0/-3/16"
	HEIGHT	2,390 +0/-5mm 7' 10 3/32" +0/-3/16"
DOOR OPENING	WIDTH	2,342 +0/-5mm 7' 8 9/64" +0/-3/16"
	HEIGHT	2,280 +0/-5mm 7' 5 45/64" +0/-3/16"
INTERNAL CUBIC CAPACITY	15.9 CU.m	561 CU.ft
MAXIMUM GROSS WEIGHT	10,160 kg	22,400 lb
TARE WEIGHT	1,300 kg	2,870 lb
MAXIMUM PAYLOAD	8,860 kg	19,530 lb
STACKING TEST LOAD(PER POST)	22,860 kg	50,397 lb
FLOOR STRENGTH LOAD	5,460 kg	12,033 lb
TITLE:		EDITION: A/O
DESIGNED:	APPROVED:	GENERAL ASSEMBLY TYPE: ISO-IDD 10'x8'x8'
CHECKED:	DATE:	TYPE: 1,300 SCALE: 1:80
PRODUCTION:		DRAWING NO. BZ10-1.00.00.0

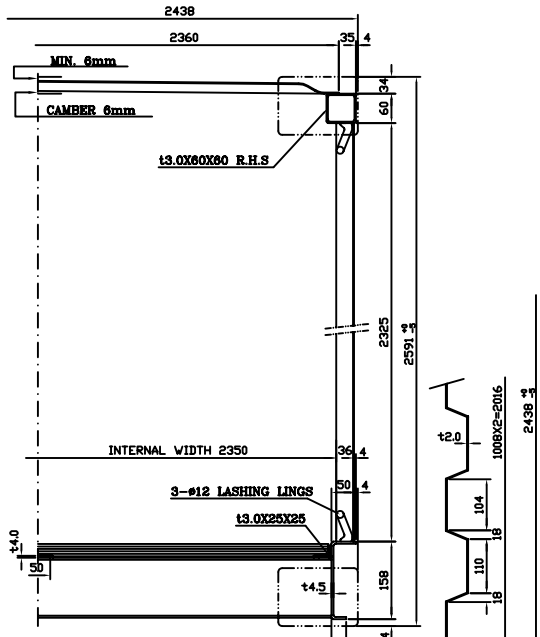
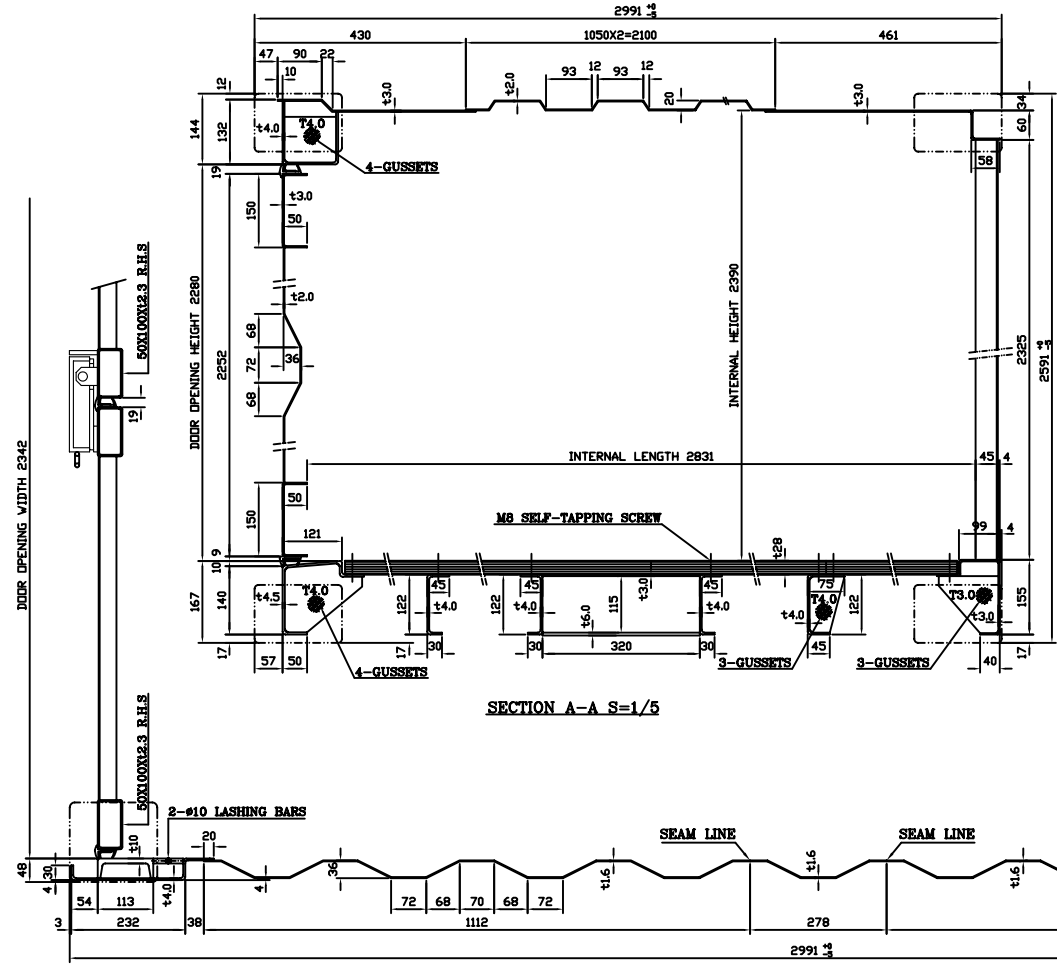
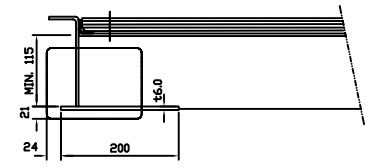
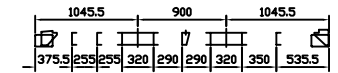
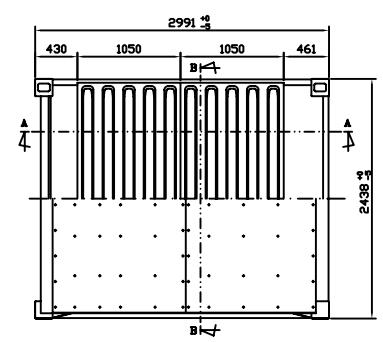
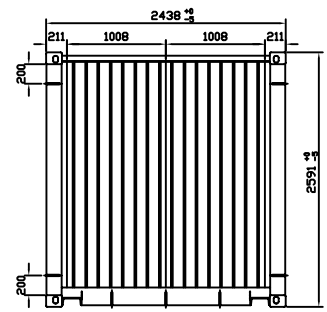
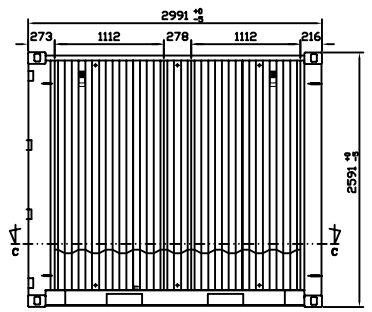
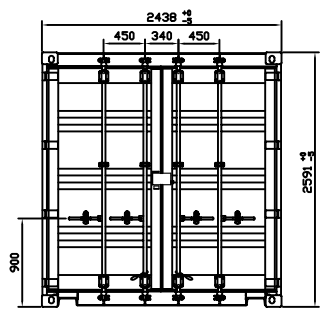
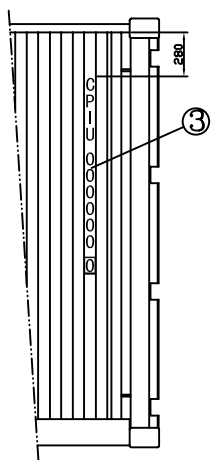

A-A  
INSIDE

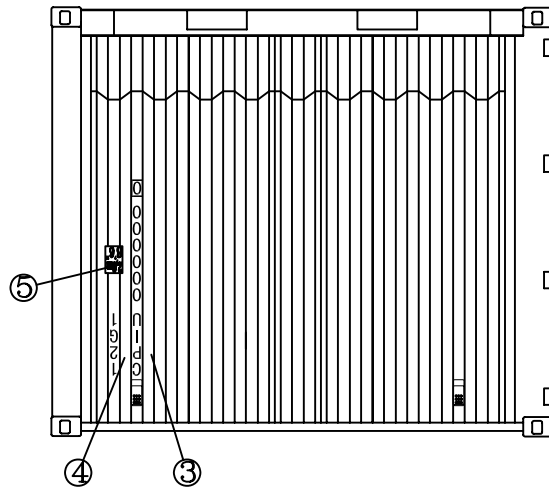

6

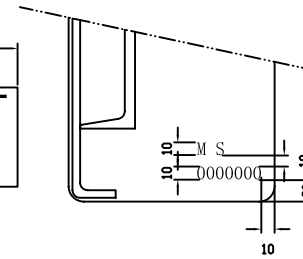

LEFT CORNER FITTING  
STAMPING OF  
MANUFACTURE'S  
SERIAL NO.

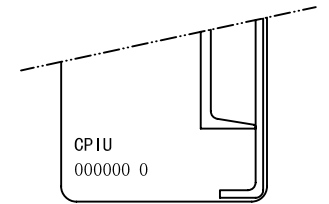

RIGHT CORNER FITTING  
STAMPING OF  
OWNER'S SERIAL NO.

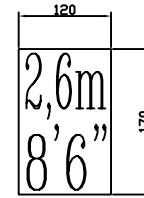
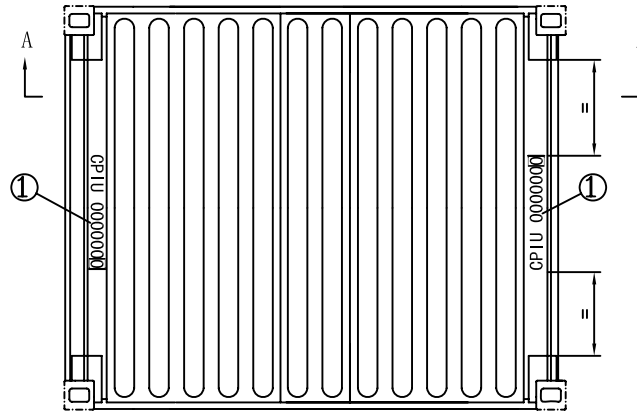
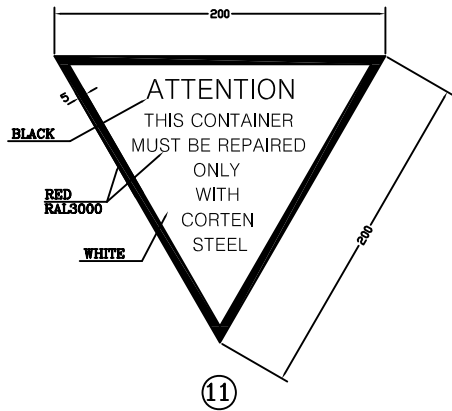

5

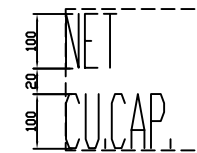
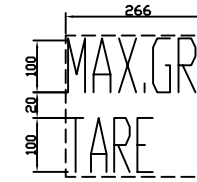

8

技术要求:

1、因此箱型需要联箱后出运，对应的箱号数量需封掉一半后出运，请注意配一半箱子的对应封标，以便出运前贴封。

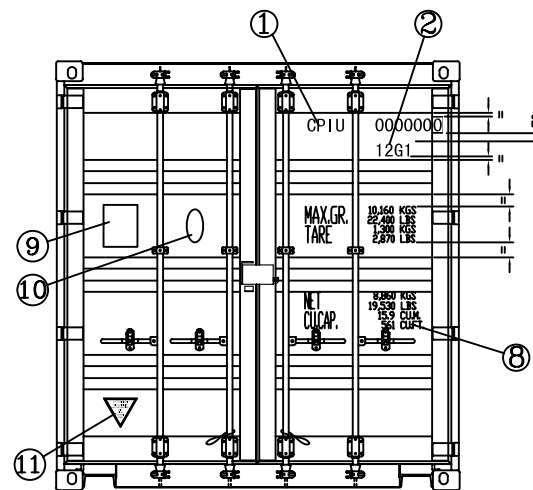
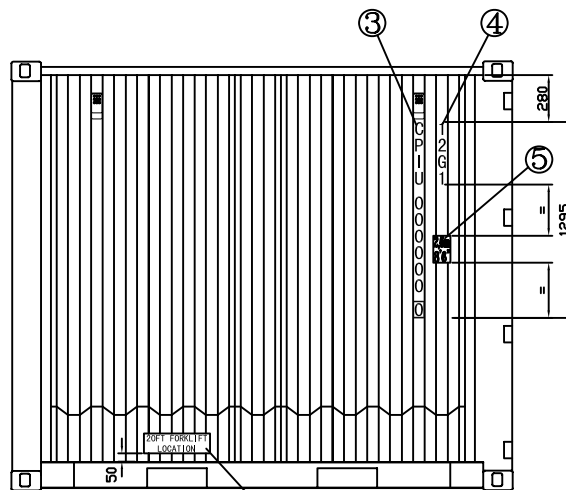
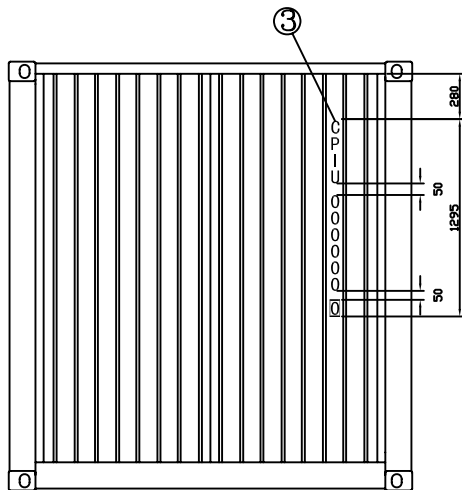

ITEM	DESCRIPTION	Q'TY	REMARK
11	REPAIRED MARK	1	RED & BLACK ON WHITE
10	CLASS EMBEL	1	CLASS SUPPLY
9	CONSOLIDATED PLATE	1	STAINLESS STEEL
8	WEIGHT&CAPACITY DECAL	1	WHITE KISS CUT
7			
6	FORKLIFT MARK	2	BLACK ON YELLOW FOR 20FT
5	HEIGHT DECAL	2	BLACK ON YELLOW
4	TYPE CODE	2	WHITE KISS CUT
3	OWNER'S CODE&SERIAL'S NO.	4	WHITE KISS CUT
2	TYPE CODE	1	WHITE KISS CUT
1	OWNER'S CODE&SERIAL'S NO.	3	WHITE KISS CUT
TITLE: CPUU			
MARKING			
OWNER: CPUU			
TYPE: 2991X8'X8'6"			
SCALE: 1:80			
DATE	QTY	REV.	DESIGNER
DATE	APPROVED	DATE	DRAWING NO.
DATE	DATE	DATE	BZ10-1.06.00.0